

***MTA1 CAN, M1 10Prog CAN, AT1 CAN,
AT1 CoarseFine CAN, M1, AT1,
AT1 CoarseFine, RA 12, RA 23,
FS 002 CAN, FS 002***



Brugsanvisning

| | |
|--|-----------|
| 1 INDLEDNING | 3 |
| 1.1 Udstyr | 3 |
| 2 DRIFT | 3 |
| 2.1 Funktioner | 3 |
| 2.2 Krydsreferenceliste fjernbetjening / maskine | 5 |
| 3 BESTILLING AF RESERVEDELE | 5 |
| MÅLSKITSE | 8 |
| SKEMA | 10 |
| BESTILLINGSNUMMER | 14 |
| TILBEHØR | 15 |

1 INDLEDNING

Disse fjernbetjeninger kan kontrollere strøm, trådfremføringshastighed, spænding eller programvalg.

ESAB's tilbehør til produktet findes på side 15.

1.1 Udstyr

Fjernbetjeningerne leveres med brugsanvisning.



FS 002 CAN og FS 002 leveres med 5 meters tilslutningskabel. Til de andre fjernbetjeninger skal tilslutningskablet bestilles separat.



2 DRIFT

Tilslut fjernbetjeningen til fjernbetjeningsudtaget på strømkilden eller trådfremføringsenheden.

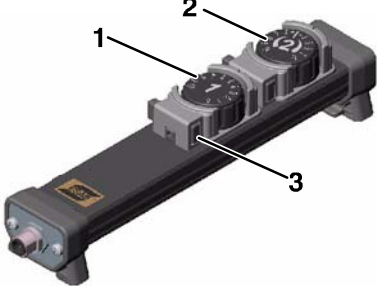
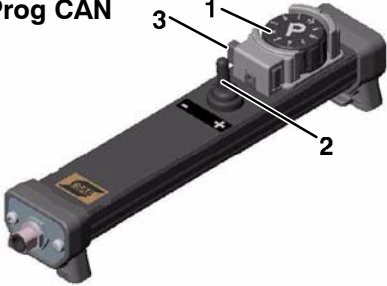
Ved tilslutning af en fjernbetjening til en Aristomaskine produceret før 2005, kan det være nødvendigt at opgradere programmet i indstillingspanelet, for at fjernbetjeningen fungerer korrekt.

2.1 Funktioner

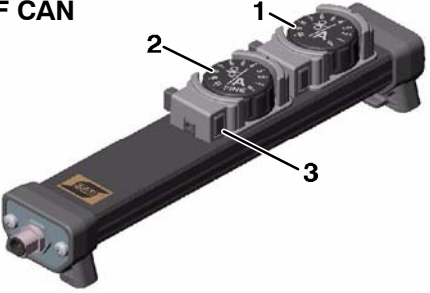
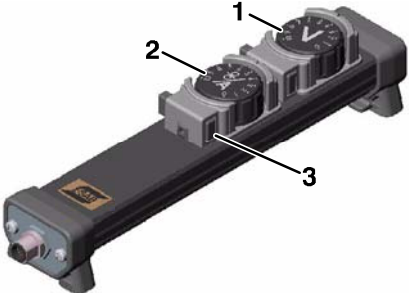
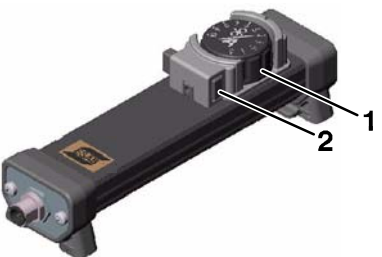
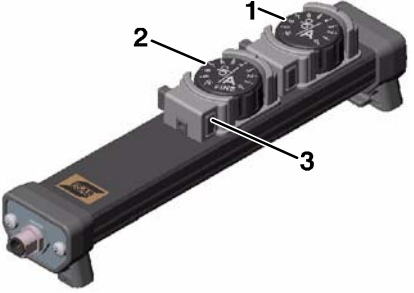
| | |
|---|---|
| <p>MTA1 CAN</p>  | <p>CAN-baseret fjernbetjening for MIG/MAG-, TIG- og MMA-svejsning.</p> <p>1 MIG/MAG: Indstilling af trådfremføringshastighed TIG: Indstilling af strøm TIG-pulssvejsning: Indstilling af pulsstrøm MMA: Indstilling af strøm</p> <p>2 MIG/MAG: Indstilling af spænding eller spændingsafvigelse +/- fra synergilinjen TIG: Ingen funktion TIG-pulssvejsning: Indstilling af grundstrøm MMA: Indstilling af buetryk</p> <p>3 Låsning af drejeknap</p> |
| <p>M1 10Prog CAN</p>  | <p>CAN-baseret fjernbetjening for MIG/MAG-, TIG- og MMA-svejsning.</p> <p>1 Valg af et af 10 programvalg</p> <p>2 MIG/MAG: Spændingsafvigelse +/- fra valgt program TIG og MMA: Indstilling af svejsestrøm +/- fra valgt program TIG-pulssvejsning: Indstilling af pulsstrøm +/- fra valgt program</p> <p>3 Låsning af drejeknap</p> |
| <p>AT1 CAN</p>  | <p>CAN-baseret fjernbetjening for MMA- og TIG-svejsning.</p> <p>1 Indstilling af strøm</p> <p>2 Låsning af drejeknap</p> |

| | |
|--|---|
| <p>AT1 CF CAN</p>  | <p>CAN-baseret fjernbetjening for MMA- og TIG-svejsning.</p> <ol style="list-style-type: none"> 1 Grovindstilling af strøm 2 Finindstilling af strøm 3 Låsning af drejeknap |
| <p>M1</p>  | <p>Fjernbetjening for MIG/MAG-svejsning</p> <ol style="list-style-type: none"> 1 Indstilling af spænding 2 Indstilling af trådfremføringshastighed 3 Låsning af drejeknap |
| <p>AT1</p>  | <p>Fjernbetjening for MMA- og TIG-svejsning.</p> <ol style="list-style-type: none"> 1 Indstilling af strøm 2 Låsning af drejeknap |
| <p>AT1 CF</p>  | <p>Fjernbetjening for MMA- og TIG-svejsning.</p> <ol style="list-style-type: none"> 1 Grovindstilling af strøm 2 Finindstilling af strøm 3 Låsning af drejeknap |
| <p>RA 12</p>  | <p>CAN-baseret fjernbetjeningsadapter. Bruges for tilslutning af fjernbetjening MMA1, MMA2 til CAN-baseret udstyr.</p> <ol style="list-style-type: none"> 1 12-polet udtag |
| <p>RA 23</p>  | <p>CAN-baseret fjernbetjeningsadapter. Bruges for tilslutning af svejsepistol med RS3-programvælger MIG2 (2 drejeknap) til CAN-baseret udstyr.</p> <ol style="list-style-type: none"> 1 23-polet udtag |

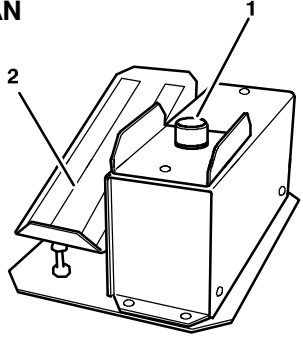
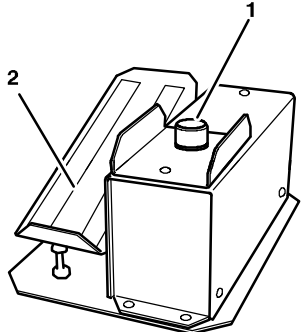
| | |
|--|--|
| <p>FS 002 CAN</p>  | <p>CAN-baseret fjernbetjening til TIG-svejsning.</p> <p>1 Potentiometer til indstilling af svejsestrøm, position 1 - 10</p> <p>2 Fodpedal til svejsestart og indstilling af strøm.</p> <p>Hvis potentiometeret sættes på 10, reguleres strømmen med fodpedalen fra min. til maks. Hvis potentiometeret sættes på 5, opnås 50 % af maks. strøm, når pedalen trykkes helt ned.</p> |
| <p>FS 002</p>  | <p>Fjernbetjening til TIG-svejsning</p> <p>1 Potentiometer til indstilling af svejsestrøm, position 1 - 10</p> <p>2 Fodpedal til svejsestart og indstilling af strøm.</p> <p>Hvis potentiometeret indstilles på 10, reguleres strømmen med fodpedalen fra min. til maks. Hvis potentiometeret sættes på 5, opnås 50 % af maks. strøm, når pedalen trykkes helt ned.</p> |

2.2 Krydsreferenceliste fjernbetjening / maskine

Se side 7.

3 BESTILLING AF RESERVEDELE

Obs!

Samtlige garantiforpligtelser fra leverandørens side ophører, hvis kunden selv i garantiperioden udfører indgreb i produktet for at afhjælpe eventuelle fejl.

Reserve dele bestilles hos nærmeste ESAB-repræsentant, se sidste side i denne publikation.

| | MTA1 CAN | M1 10P CAN | AT1 CAN | AT1 CF CAN | M1 | AT1 | AT1 CF | RA12 | RA23 | FS 002 CAN | FS 002 |
|-------------------------|-------------|---------------|------------|---------------|----|-----|--------|------|------|---------------|--------|
| DTF | | | | | | X | X | | | | X |
| DTE/DTG | | | | | | X | X | | | | X |
| LHF | | | | | | X | X | | | | X |
| Professional | | | | | | X | X | | | | X |
| LTN/LTR | | | | | | X | X | | | | X |
| Arc 150i | | | | | | X | X | | | | X |
| Tig 150i/200i | | | | | | X | X | | | | X |
| Feed 304/484, M12 | | | | | X | | | | X | | |
| Feed 304/484, M13 | | | | | X | | | | | | |
| ESABFeed M14 | | | | | X | | | | | | |
| MEK (23-polig) | | | | | X | | | | | | |
| Feed 3004/4804, M2 | X | | | | | | | | X | | |
| Feed 3004/4804, MA4 | X | | X | | | | | | X | | |
| Feed 3004/4804, MA6 | X | X | X | X | | | | X | X | | |
| Feed 3004/4804, U6 | X | X | X | X | | | | X | X | X | |
| Feed 3004/4804, M0 / U8 | X | X | X | X | | | | X | X | X | |
| Arc 4000i/5000i, A2 | X | | X | X | | | | X | | | |
| Arc 4000i/5000i, A4 | X | | X | X | | | | X | | | |
| Tig 4000i, T4 | X | | X | X | | | | X | | X | |
| Tig 4000i, T6 | X | X | X | X | | | | X | | X | |

Målskitse

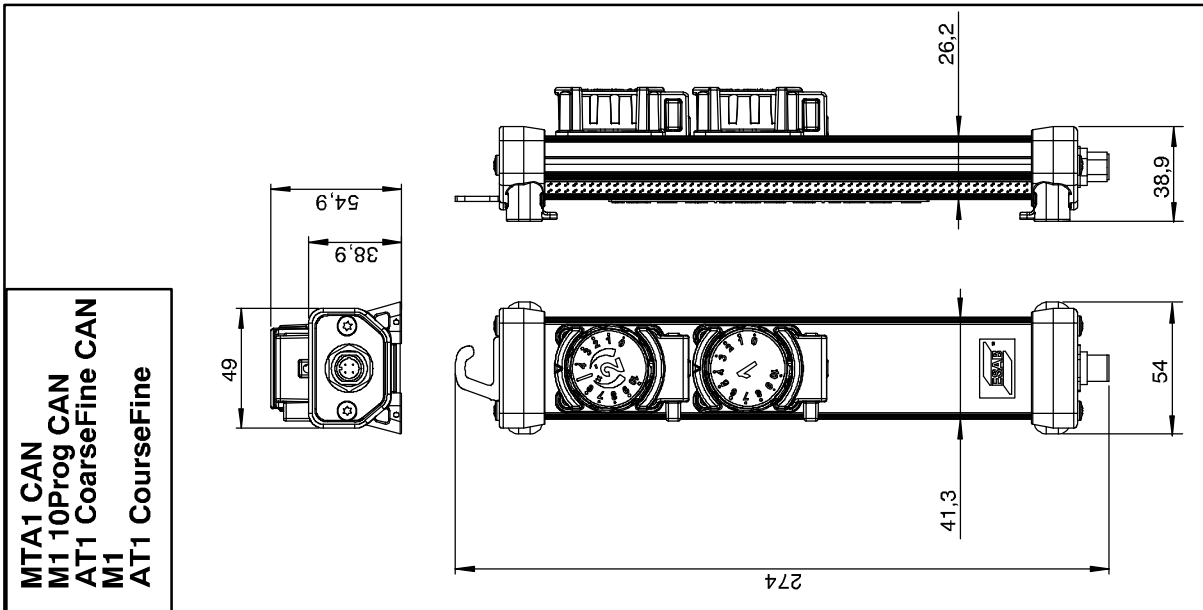
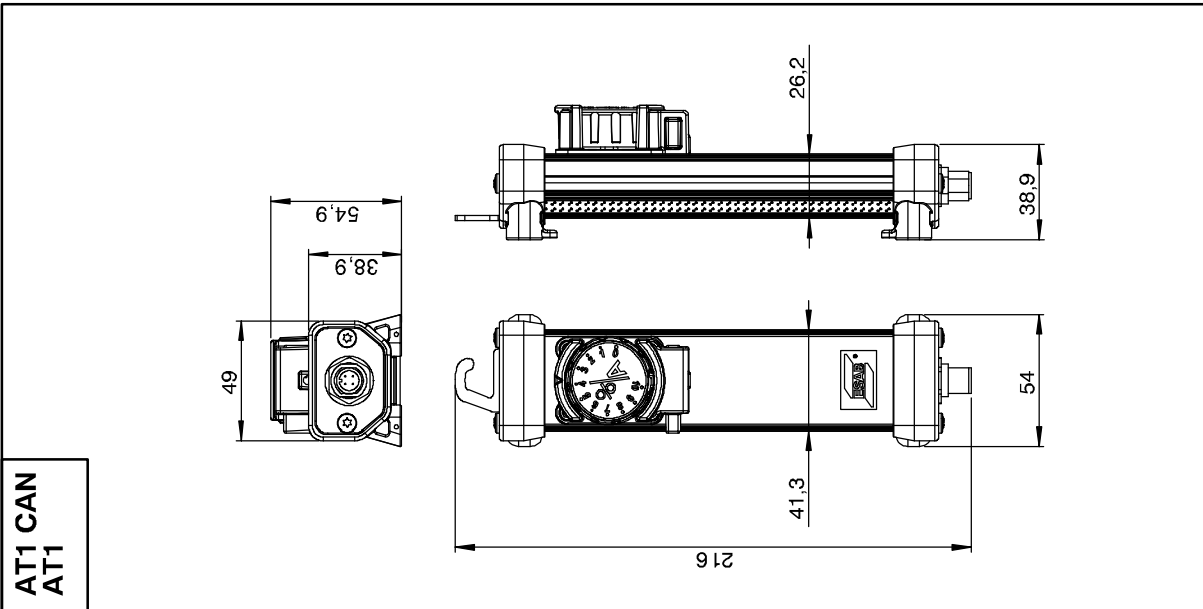
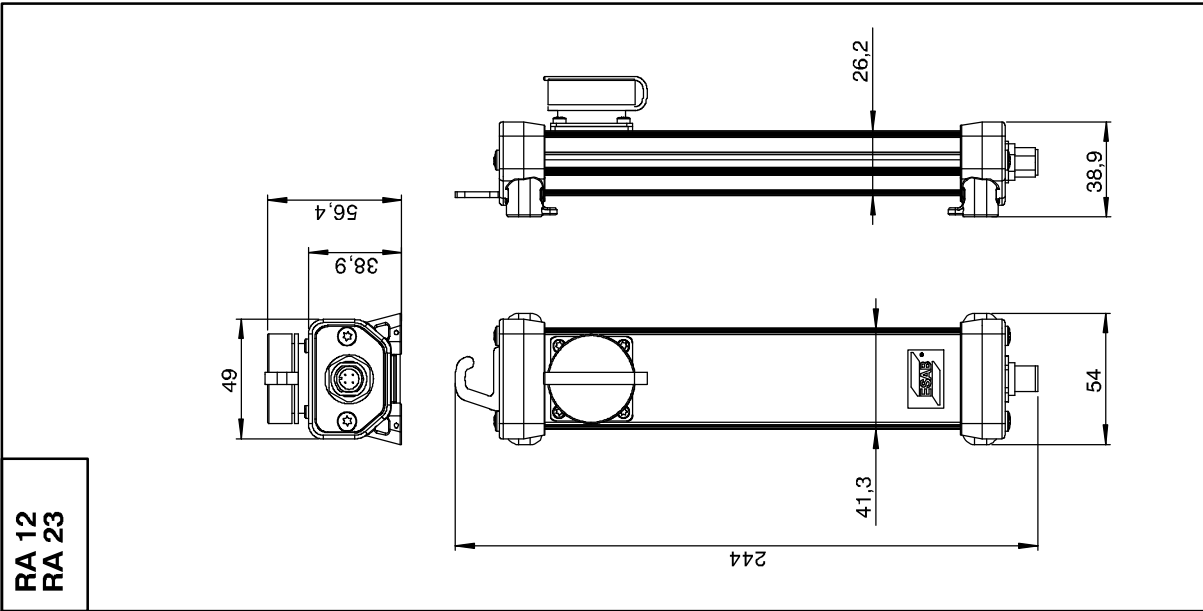

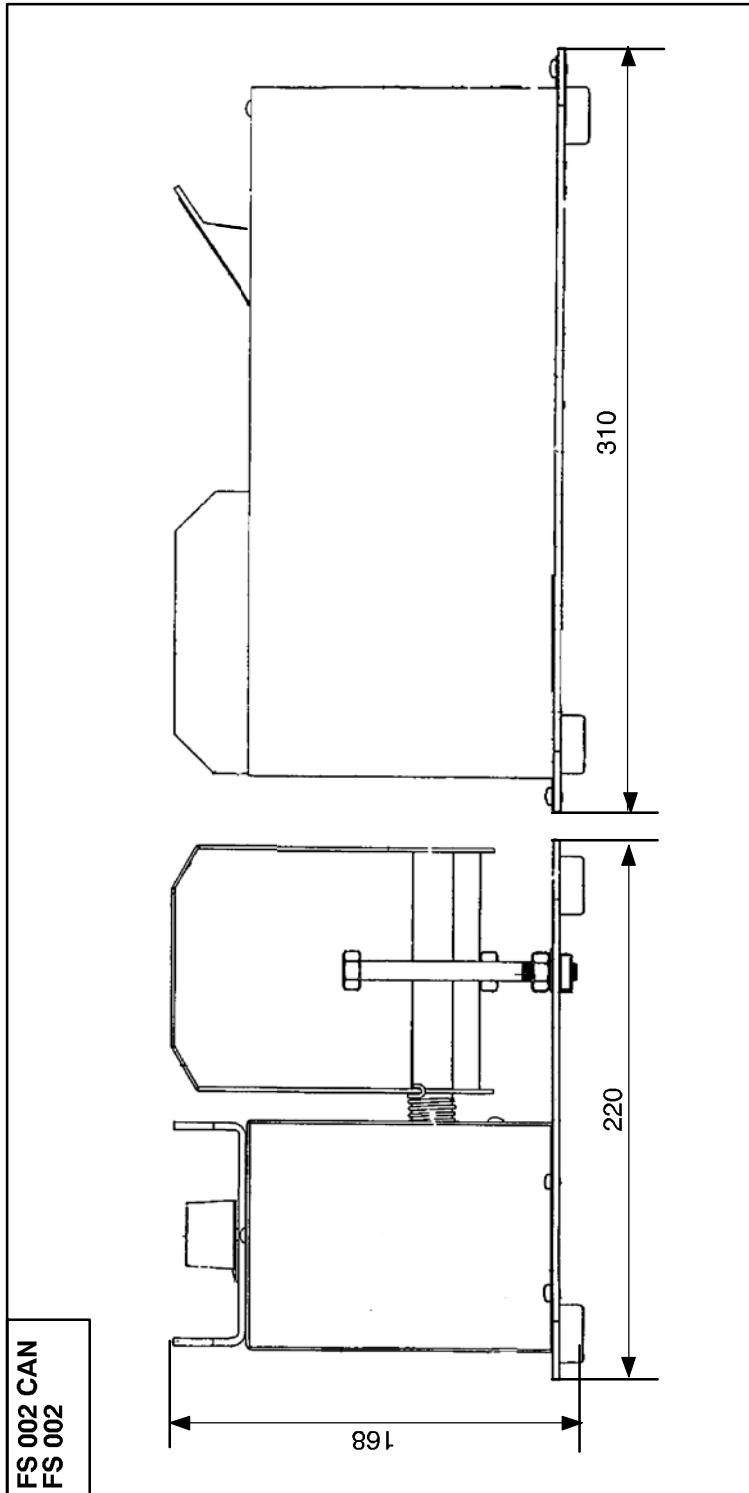

Skema

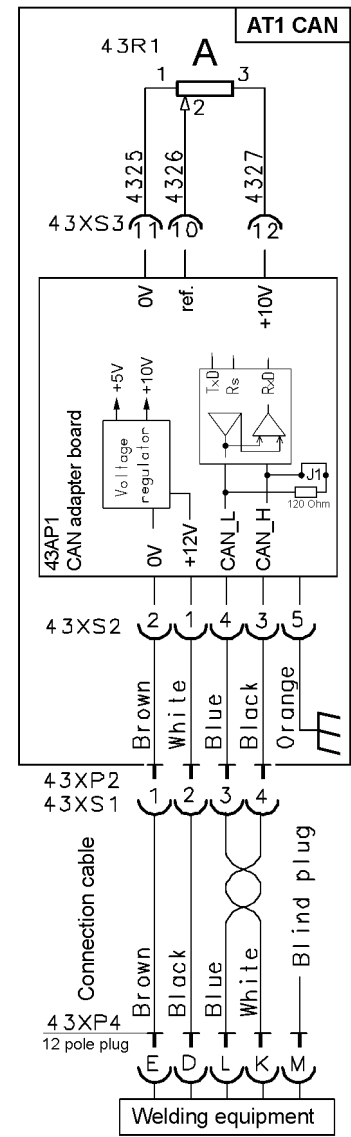
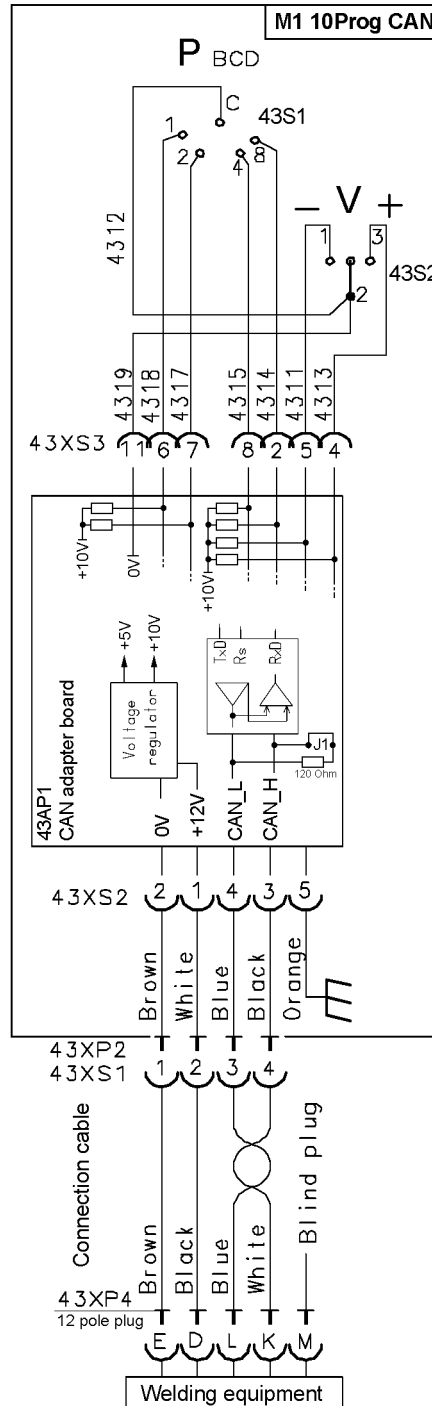
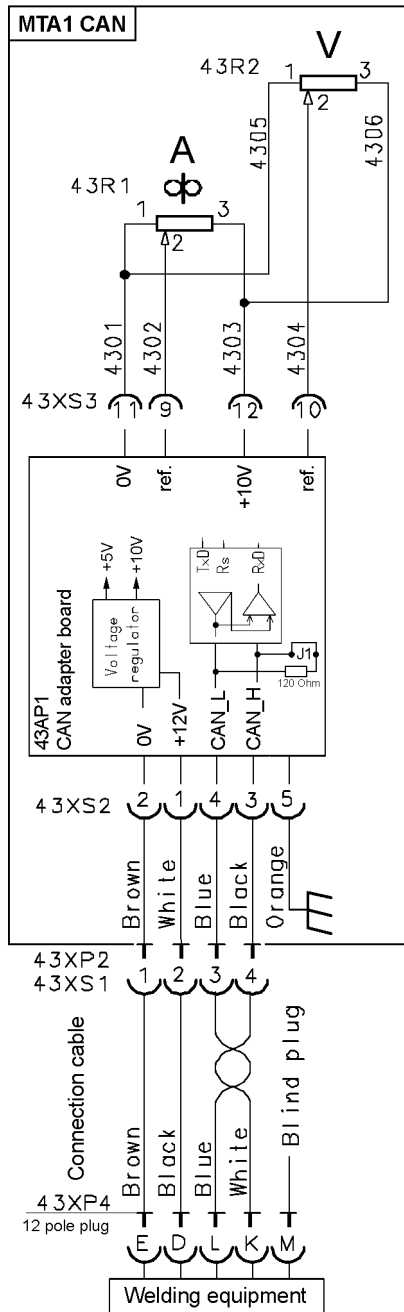

Valid for serial number
506-xxx-xxx

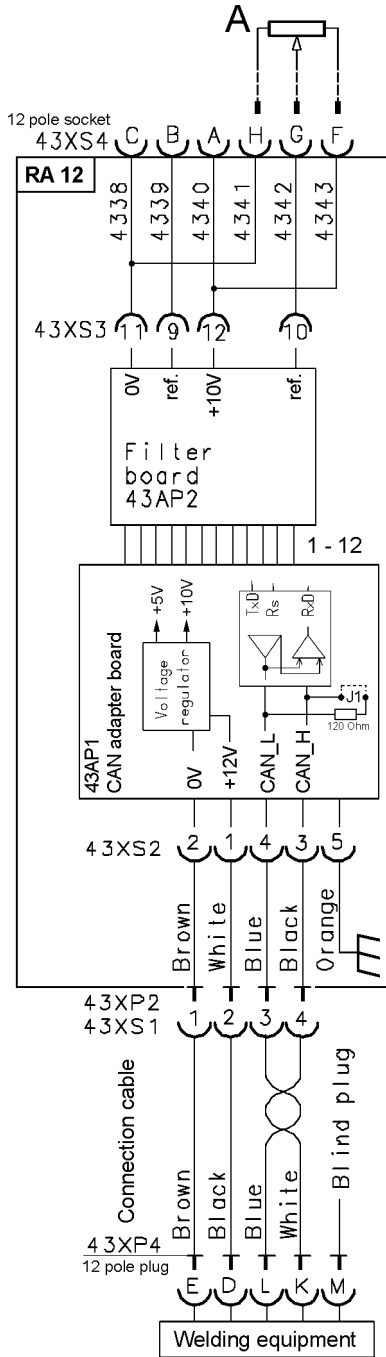

Valid for serial number
638-xxx-xxx

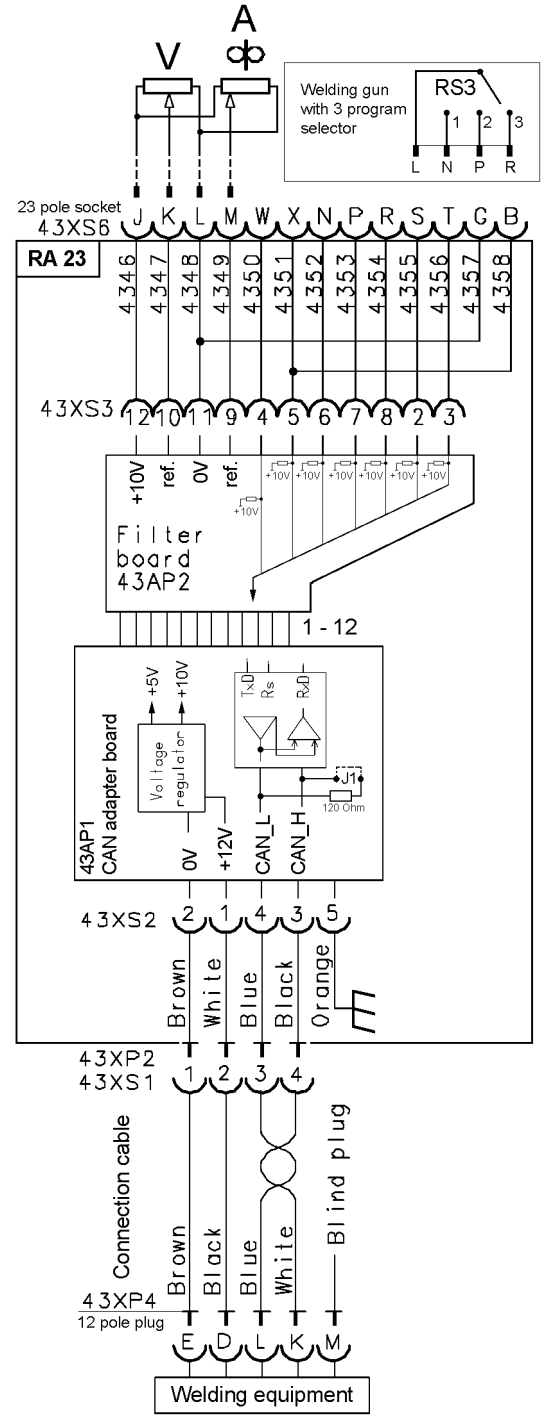
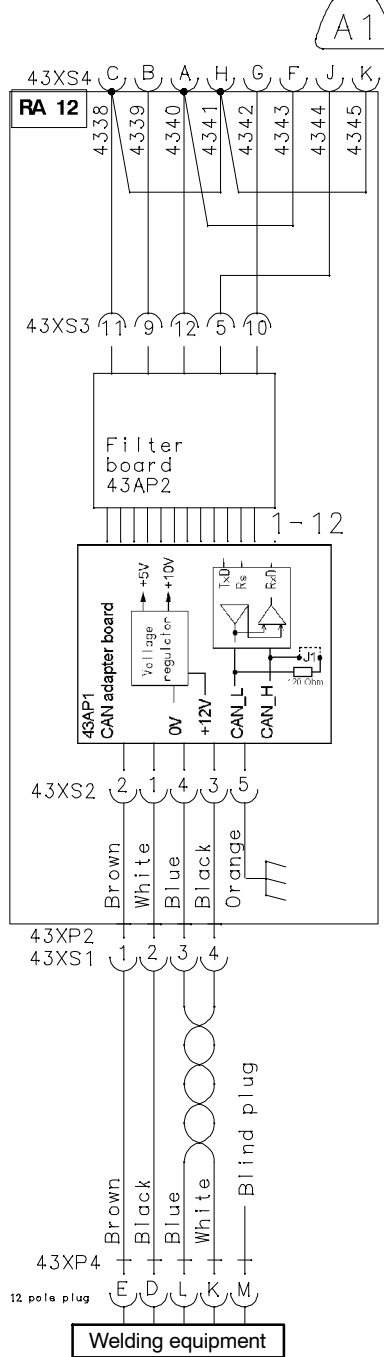

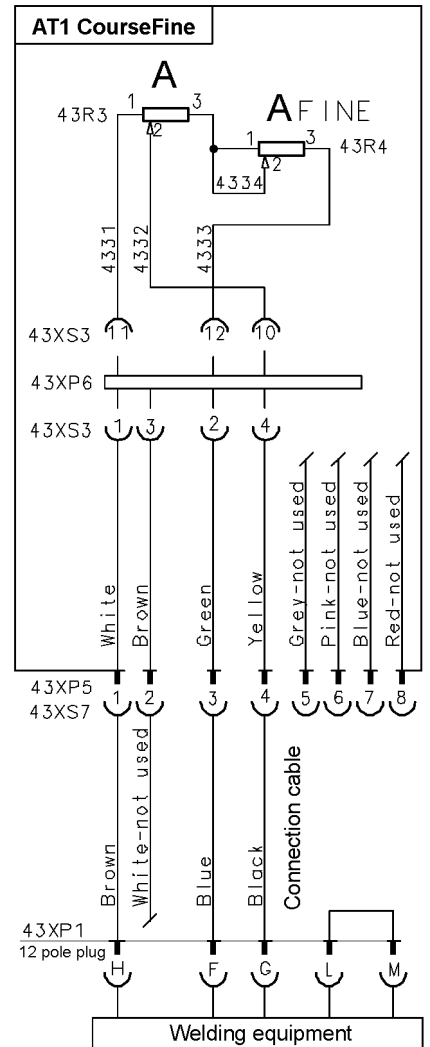
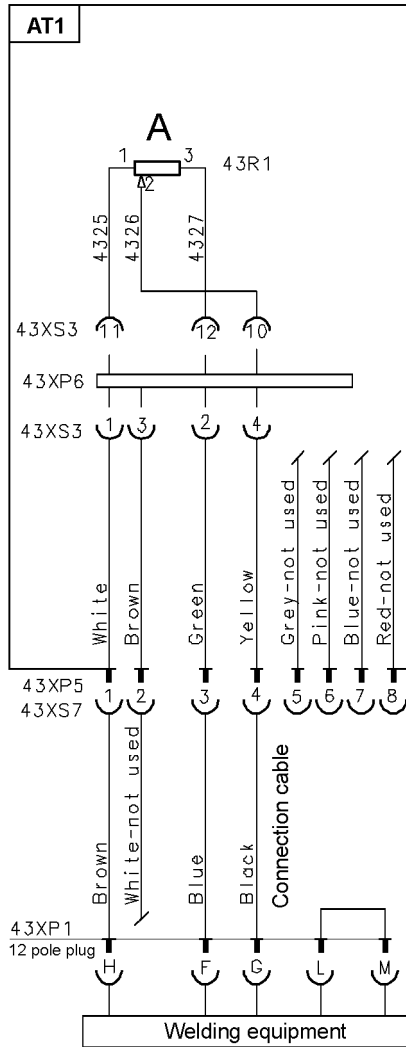
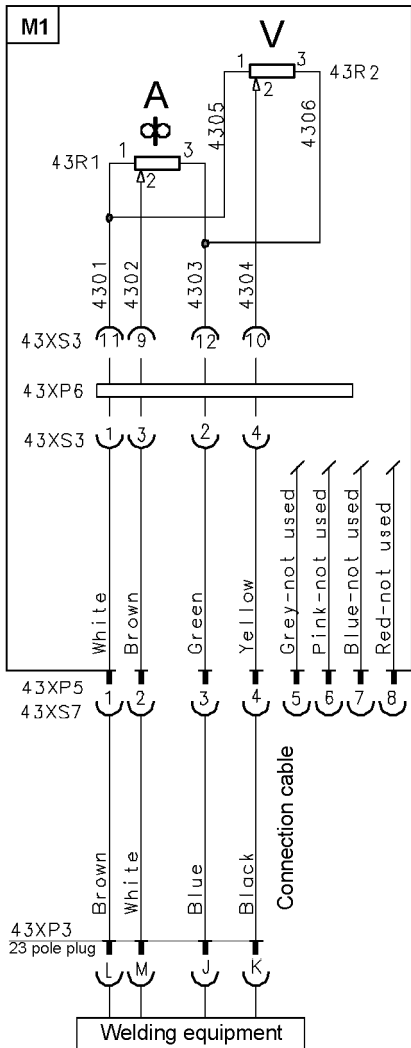

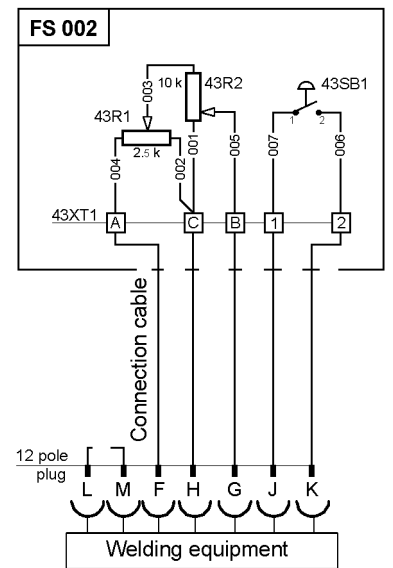
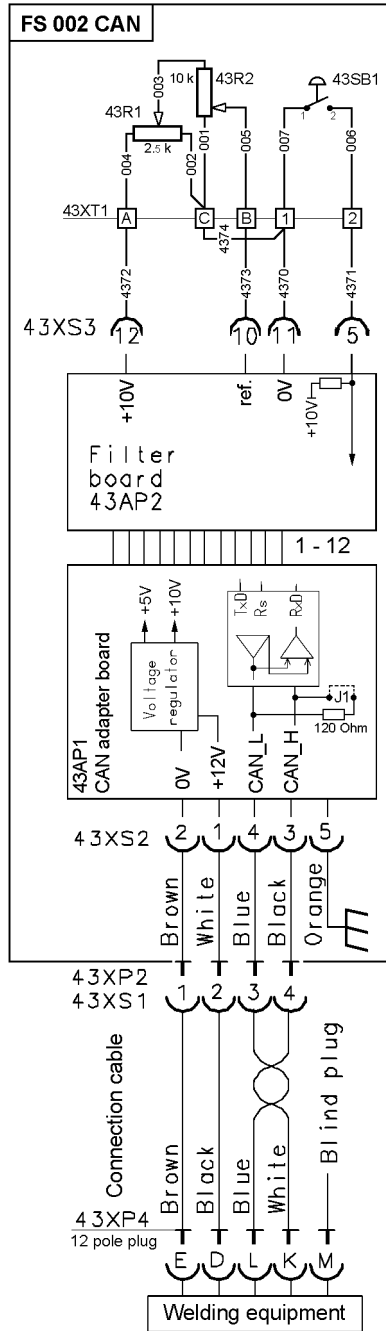
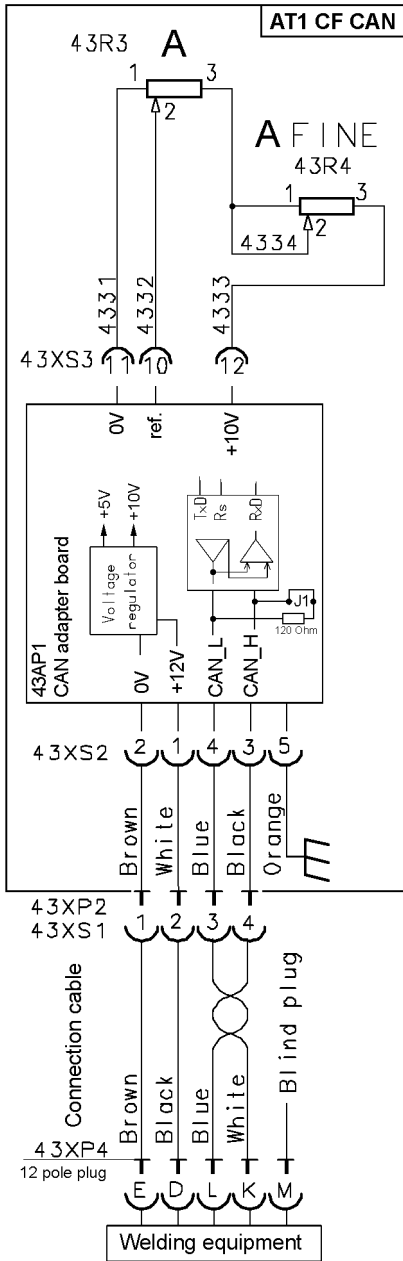

Bestillingsnummer

| Remote control | Ordering no. | Remote control | Ordering no. |
|--|--------------|--|--------------|
| MTA1 CAN  | 0459 491 880 | M1  | 0459 491 895 |
| M1 10Prog CAN  | 0459 491 882 | AT1  | 0459 491 896 |
| AT1 CAN  | 0459 491 883 | AT1 CoarseFine  | 0459 491 897 |
| AT1 CoarseFine CAN  | 0459 491 884 | RA 12  | 0459 491 910 |
| FS 002 CAN  | 0349 090 890 | RA 23  | 0459 491 911 |
| FS 002  | 0349 090 886 | | |

Spare parts list 0459 576 990

The spare parts list is available on the Internet at www.esab.com

Tilbehør

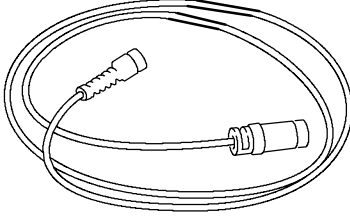
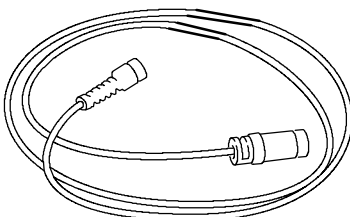
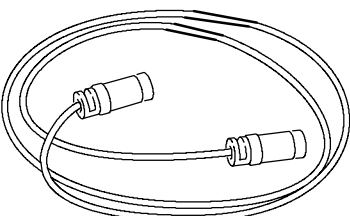
| | |
|---|--|
|  | <p>Remote cable CAN 4 pole - 12 pole</p> <p>5 m 0459 554 880</p> <p>10 m 0459 554 881</p> <p>15 m 0459 554 882</p> <p>25 m 0459 554 883</p> <p>0.25 m 0459 554 884</p> <p>5 m Heavy Duty 0459 554 980</p> <p>Remote cable CAN 4 pole - 10 pole for Yard Feed 2000</p> <p>5 m 0459 960 880</p> <p>5 m Heavy Duty 0459 960 980</p> |
|  | <p>Remote cable 8 pole - 12 pole for remote controls AT1 and AT1 CF</p> <p>5 m 0459 552 880</p> <p>10 m 0459 552 881</p> <p>15 m 0459 552 882</p> <p>25 m 0459 552 883</p> <p>Remote cable 8 pole - 23 pole for remote control M1</p> <p>5 m 0459 553 880</p> |
|  | <p>Extension cable 12 pole for remote controls AT1, AT1 CF and FS 002</p> <p>25 m 0367 662 880</p> |

ESAB subsidiaries and representative offices

Europe

AUSTRIA

ESAB Ges.m.b.H
Vienna-Liesing
Tel: +43 1 888 25 11
Fax: +43 1 888 25 11 85

BELGIUM

S.A. ESAB N.V.
Brussels
Tel: +32 2 745 11 00
Fax: +32 2 745 11 28

THE CZECH REPUBLIC

ESAB VAMBERK s.r.o.
Vamberk
Tel: +420 2 819 40 885
Fax: +420 2 819 40 120

DENMARK

Aktieselskabet ESAB
Herlev
Tel: +45 36 30 01 11
Fax: +45 36 30 40 03

FINLAND

ESAB Oy
Helsinki
Tel: +358 9 547 761
Fax: +358 9 547 77 71

FRANCE

ESAB France S.A.
Cergy Pontoise
Tel: +33 1 30 75 55 00
Fax: +33 1 30 75 55 24

GERMANY

ESAB GmbH
Solingen
Tel: +49 212 298 0
Fax: +49 212 298 218

GREAT BRITAIN

ESAB Group (UK) Ltd
Waltham Cross
Tel: +44 1992 76 85 15
Fax: +44 1992 71 58 03

ESAB Automation Ltd

Andover
Tel: +44 1264 33 22 33
Fax: +44 1264 33 20 74

HUNGARY

ESAB Kft
Budapest
Tel: +36 1 20 44 182
Fax: +36 1 20 44 186

ITALY

ESAB Saldatura S.p.A.
Mesero (Mi)
Tel: +39 02 97 96 81
Fax: +39 02 97 28 91 81

THE NETHERLANDS

ESAB Nederland B.V.
Utrecht
Tel: +31 30 2485 377
Fax: +31 30 2485 260

NORWAY

AS ESAB
Larvik
Tel: +47 33 12 10 00
Fax: +47 33 11 52 03

POLAND

ESAB Sp.zo.o.
Katowice
Tel: +48 32 351 11 00
Fax: +48 32 351 11 20

PORTUGAL

ESAB Lda
Lisbon
Tel: +351 8 310 960
Fax: +351 1 859 1277

SLOVAKIA

ESAB Slovakia s.r.o.
Bratislava
Tel: +421 7 44 88 24 26
Fax: +421 7 44 88 87 41

SPAIN

ESAB Ibérica S.A.
Alcalá de Henares (MADRID)
Tel: +34 91 878 3600
Fax: +34 91 802 3461

SWEDEN

ESAB Sverige AB
Gothenburg
Tel: +46 31 50 95 00
Fax: +46 31 50 92 22

ESAB international AB

Gothenburg
Tel: +46 31 50 90 00
Fax: +46 31 50 93 60

SWITZERLAND

ESAB AG
Dietikon
Tel: +41 1 741 25 25
Fax: +41 1 740 30 55

North and South America

ARGENTINA

CONARCO
Buenos Aires
Tel: +54 11 4 753 4039
Fax: +54 11 4 753 6313

BRAZIL

ESAB S.A.
Contagem-MG
Tel: +55 31 2191 4333
Fax: +55 31 2191 4440

CANADA

ESAB Group Canada Inc.
Mississauga, Ontario
Tel: +1 905 670 02 20
Fax: +1 905 670 48 79

MEXICO

ESAB Mexico S.A.
Monterrey
Tel: +52 8 350 5959
Fax: +52 8 350 7554

USA

ESAB Welding & Cutting Products
Florence, SC
Tel: +1 843 669 44 11
Fax: +1 843 664 57 48

Asia/Pacific

CHINA

Shanghai ESAB A/P
Shanghai
Tel: +86 21 5308 9922
Fax: +86 21 6566 6622

INDIA

ESAB India Ltd
Calcutta
Tel: +91 33 478 45 17
Fax: +91 33 468 18 80

INDONESIA

P.T. ESABindo Pratama
Jakarta
Tel: +62 21 460 0188
Fax: +62 21 461 2929

JAPAN

ESAB Japan
Tokyo
Tel: +81 3 5296 7371
Fax: +81 3 5296 8080

MALAYSIA

ESAB (Malaysia) Snd Bhd
Selangor
Tel: +60 3 8027 9869
Fax: +60 3 8027 4754

SINGAPORE

ESAB Asia/Pacific Pte Ltd
Singapore
Tel: +65 6861 43 22
Fax: +65 6861 31 95

SOUTH KOREA

ESAB SeAH Corporation
Kyungnam
Tel: +82 55 269 8170
Fax: +82 55 289 8864

UNITED ARAB EMIRATES

ESAB Middle East FZE
Dubai
Tel: +971 4 887 21 11
Fax: +971 4 887 22 63

Representative offices

BULGARIA

ESAB Representative Office
Sofia
Tel/Fax: +359 2 974 42 88

EGYPT

ESAB Egypt
Dokki-Cairo
Tel: +20 2 390 96 69
Fax: +20 2 393 32 13

ROMANIA

ESAB Representative Office
Bucharest
Tel/Fax: +40 1 322 36 74

RUSSIA

LLC ESAB
Moscow
Tel: +7 095 543 9281
Fax: +7 095 543 9280

LLC ESAB

St Petersburg
Tel: +7 812 336 7080
Fax: +7 812 336 7060

Distributors

For addresses and phone numbers to our distributors in other countries, please visit our home page

www.esab.com



ESAB AB
SE-695 81 LAXÅ
SWEDEN
Phone +46 584 81 000



www.esab.com